

Curved Blade Register – Two Way

DAC2VM

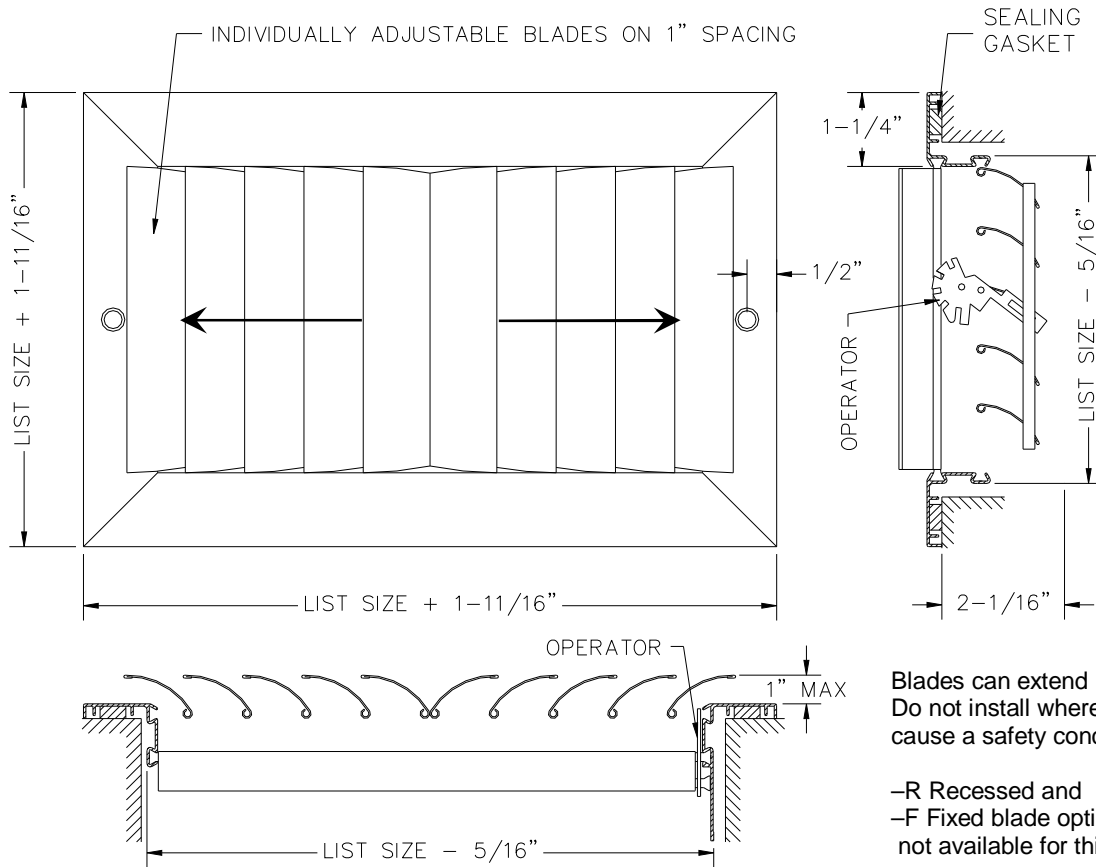

- Two-way individually adjustable vertical curved blades on 1" spacing allows a wider spread of air to be achieved
- Multi-Shutter Damper with handle operator
- Roll-formed aluminum blade installed in an extruded aluminum frame with mechanically locked corners
- Pressure fit nylon pivot pins (rattle free & non-loosening)
- Countersunk screw holes c/w painted mounting screws
- Sealing gasket to prevent streaking of walls or ceiling
- Available on 2" increments as standard
- Custom sizes available, but extra charge may apply
- Max blade length is 22", mullions used for larger sizes
- Durable powder coat painted finish
- Available in White, Silver or Mill



MODEL	DAC2VM
FACE BLADES	Vertical Adjustable
REAR BLADES	n/a
DAMPER	Multi-Shutter
MATERIAL	Aluminum
COLOR	White/Silver/Mill

JOB NAME: _____

LOCATION: _____

ARCHITECT: _____

ENGINEER: _____

CONTRACTOR: _____